

## TYPICAL BITUMINOUS PATCH AROUND CASTINGS DETAIL

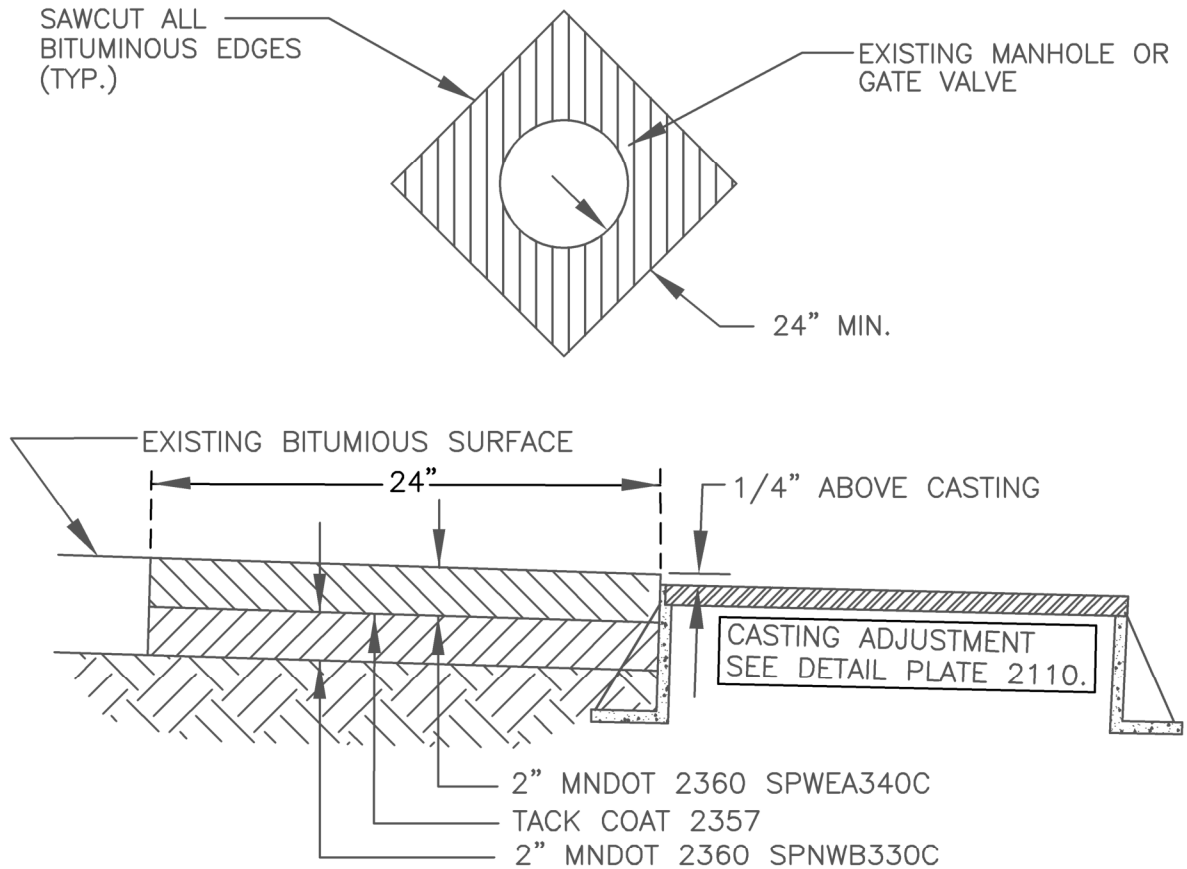

### PATCHING NOTES:

1. SAW CUT AND TACK ALL EDGES, REMOVE BITUMINOUS PATCH AREA AND ENOUGH CLASS 5 MATERIAL TO ACCOMMODATE BITUMINOUS PATCH.
2. MECHANICAL COMPACTION OF GRAVEL BASE REQUIRED PRIOR TO PAVING.
3. CONTRACTOR MAY USE WEAR COURSE MATERIAL IN LIEU OF BASE COURSE MATERIAL.
4. USE VIBRATORY SLED TAMPER ON BASE COURSE PATCH.
5. ALLOW BASE COURSE TO FULLY COOL BEFORE PLACING WEAR COURSE.
6. ONLY MNDOT APPROVED RELEASE AGENTS MAY BE USED OVER CASTINGS.
7. RE-APPLY TACK TO ALL EDGES (IF NEEDED) AND PATCHED BASE AREA.
8. ROLL PATCH FROM EDGES TO CENTER. REMOVE OR ADD MATERIAL DURING ROLLING SO PATCH IS TRUE AND LEVEL WITH SURROUNDING SURFACES. CONTRACTOR TO STRINGLINE ALL PATCHES PRIOR TO APPROVAL.
9. MNDOT 2360—ORDINARY COMPACTION METHOD REQUIRED.
10. PATCHED AREAS SHALL MATCH ROADS EXISTING THICKNESS FOR SECTION.
11. IF CASTING NEEDS TO BE ADJUSTED SEE DETAIL PLATE 2110.



**CITY OF  
CHANHASSEN**

TYPICAL STREET PATCHING  
AT MANHOLES OR  
GATE VALVES (BITUMINOUS)

REVISED: 12-19

FILE NAME: G:\ENG\SPECS\5202B

ENGINEERING DEPARTMENT

PLATE NO.:

5202B