

FRONT ELEVATION

RIGHT SIDE ELEVATION

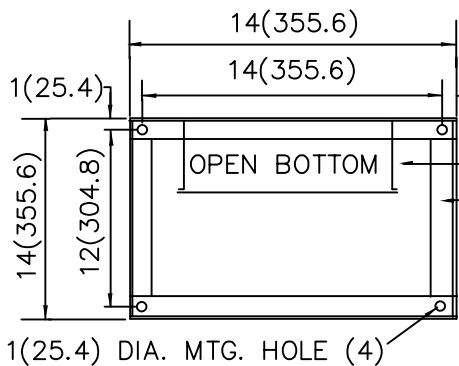

BASE LAYOUT

* 2 Cabinet keys to be furnished with each cabinet.

CONSTRUCTION NOTES:

1. SERVICE CABINET SHALL BE FABRICATED FROM #12 GAUGE ALL FORMED AND WELDED GALVANIZED STEEL FOR OUTDOOR WEATHERPROOF SERVICE W/HINGED GASKETED DOOR SECURED W/3-PT. PADLOCKABLE VAULT TURN HANDLE. HINGES SHALL BE S.S. W/BRASS PIN AND SECURED TO CABINET W/NON-CORROSIVE TAMPERPROOF CARRIAGE BOLTS. EXPOSED SURFACES SHALL BE PAINTED A PRIMER SHOP COAT OF RED OXIDE MHD 3507 AND AN OVEN BAKED DARK GREEN ENAMEL, MHD 3552.
2. SERVICE CABINETS SHALL BE UL LISTED AND LABELED "SUITABLE FOR USE AS SERVICE ENTRANCE EQUIPMENT".



**CITY OF
CHANHASSEN**

STREET LIGHT
SERVICE CABINET

REVISED: 1-10

FILE NAME: G:\ENG\SPECS\5242

ENGINEERING DEPARTMENT

PLATE NO.:

5242