

BIT. WEAR COURSE ADJ. DETAIL

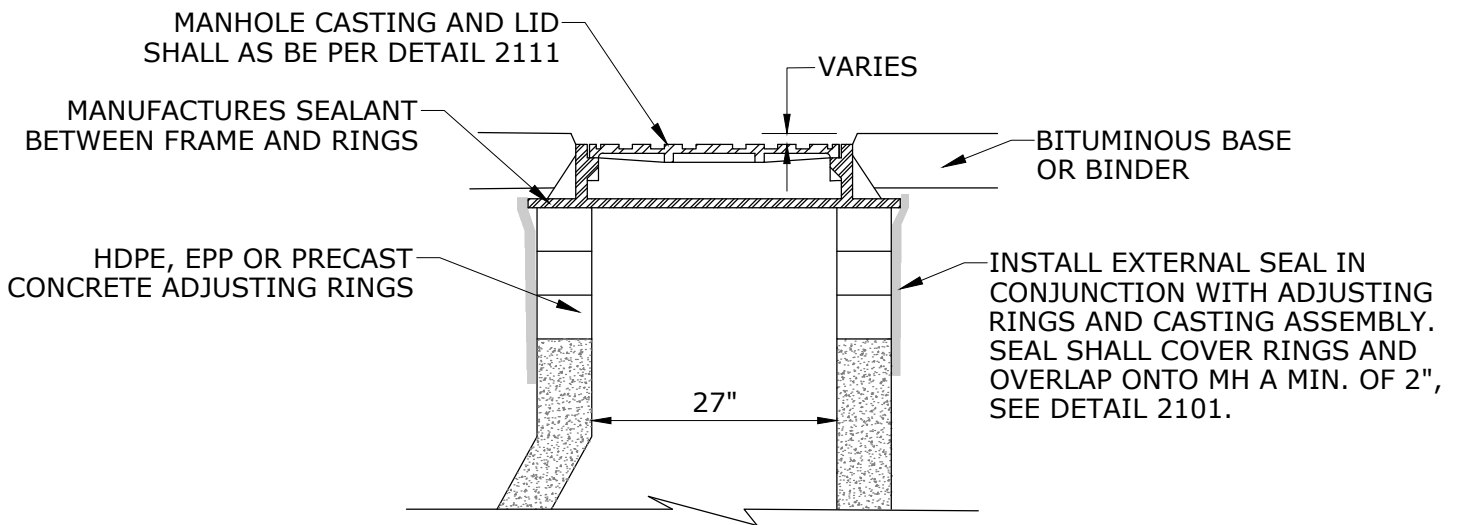

BIT. BASE OR BINDER COURSE ADJ. DETAIL

NOTES:

1. MINIMUM OF 2-2" ADJUSTING RINGS, MAXIMUM OF 3 ADJUSTING RINGS AND A TOTAL MAXIMUM STACK HEIGHT OF 12" FOR NEW CONSTRUCTION.
2. PRECAST CONCRETE ADJUSTING RINGS SHALL BE BEDDED WITH 1/4" TO 1/2" MORTAR.
3. HDPE AND EPP ADJUSTING RINGS SHALL BE INSTALLED WITH MANUFACTURES SEALANT OR APPROVED EQUAL.
4. ALL ADJUSTMENTS SHALL INCLUDE NEW RINGS FROM CASTING TO CONE.
5. WOOD SHIMS ARE NOT PERMITTED TO BE USED IN ADJUSTING RINGS.
6. WEAR COURSE SHALL USE STEEL ADJUSTING RING INSERTS PER MANUFACTURES SPECS. WITH ENGINEERS APPROVAL.
7. 2-PIECE COVER RISER RINGS ARE NOT ALLOWED.
8. TOTAL OFFSET FOR ALL RINGS SHALL NOT EXCEED 4" WITHOUT CITY ENGINEERS APPROVAL.



MANHOLE CASTING AND ADJUSTING DETAIL

REVISED: 2-24

ENGINEERING DEPARTMENT

PLATE NO.:

2110